

Specifications

HPH-8

Trigger cable	120-volt, Nema 1-15
Main Power	50-amps @ 240-volt AC
Power receptacles (4)	Nema 5-15 or 6-15
Maximum HID wattage	8000 watts (on 240-volt) 4800 watts (on 120-volt)
Maximum number of HID ballast	Eight (8) ballast
Weight / Dimensions	13 lbs / 7.37" x 5" x 10"
Life Expectancy	> 10 years

All Sentinel Timers and controllers offer a **3-year** warranty.

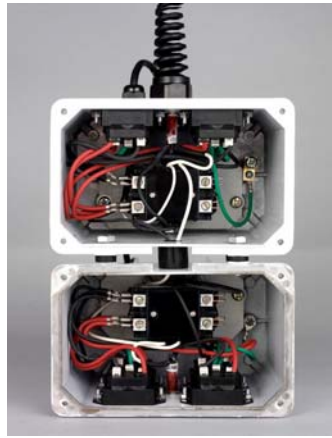

Sentinel products are distributed by:

GPS / Global Product Solutions LLC.



www.growgps.com



Instruction Manual

HPH-8

High Power HID controller



Introduction

When trying to control more than one HID (High Intensity Discharge) lighting system, you can either use a bunch of timers OR... a device like the HPH-8. The HPH-8 makes it simple to control up to 8000 watts of lighting from a single timer or controller. The HPH-8 has eight **UNIVERSAL** receptacles that accept **either** a **120 volt** (Nema 5-15P) or **240 volt** (Nema 6-15P) male plug from your HID ballasts.

The user provides a single 240 volt, 50-amp circuit to the HPH-8. An internal heavy-duty relay switches the lights On and Off. The relay is turned On and Off by connecting the 15 ft “trigger cable” (a 120 volt power cable) to a timeclock or controller like the MDT-1. When the timeclock or controller turns ON, the trigger cable carries the voltage to the relay inside the HPH-8, the relays activate, and the (8) receptacles are energized turning the lights connected to the unit ON.

The HPH-8 is housed in a sealed, aluminum heat sink enclosure and can be mounted using the wall mount bracket included.

Heat from the relays and internal components is radiated outside the enclosure to ensure long life and cool operation.

The user must provide and connect a 240 volt, 50-amp circuit to the HPH-8 (see below)

TABLE OF CONTENTS

A quick look at the HPH-8
Installation of the HPH-8
Using the HPH-8
Connection Examples
HPH-8 electrical connections 240 volt
*120-Volt Option
Troubleshooting & Specs

WARNING: Installation must be completed by qualified person(s). Installation must be done in accordance with state and local electrical codes.

Troubleshooting

Some of the more common questions and problems are listed here.

Problem: The timeclock or controller is turning On the relay and red indicator light but the lights are not turning ON.

Check the main power. If the relay is turned ON, and the ballasts are connected, the main power may not be turned ON.

Problem: The red indicator and relay do not turn ON.

Check the timeclock or controller that the trigger cable is connected to. The trigger cable provides a 120-volt “signal” to the HPH-8 that turns ON the relay and red indicator. Try plugging the trigger cable into a known 120-volt power source. If it works, then the problem is with the timeclock or controller you are using to turn the HPH-8 ON.

Problem: The circuit breaker for the main power keeps shutting OFF.

The circuit breaker is protecting the circuit from overloading. It is possible that one or more of the ballasts have failed (shorted out). Try unplugging each ballast one at a time to determine which ballast has a problem.

It is also possible that the amperage is too much for the circuit breaker. Verify the circuit breaker is a 50-amp, 2-pole breaker.

Problem: The red light and relay are OFF but the lights remain ON.

It is possible that something is wrong with the heavy-duty relay. If the trigger cable is unplugged and the HID lights remain ON, contact the factory.

Problem: The red light is ON but I do not hear the relay turning ON and the lights do not turn ON.

It is possible that something is wrong with one of the heavy-duty relays. If the red light is ON, and the lights do not turn ON, contact the factory.

A quick look at the HPH-8...

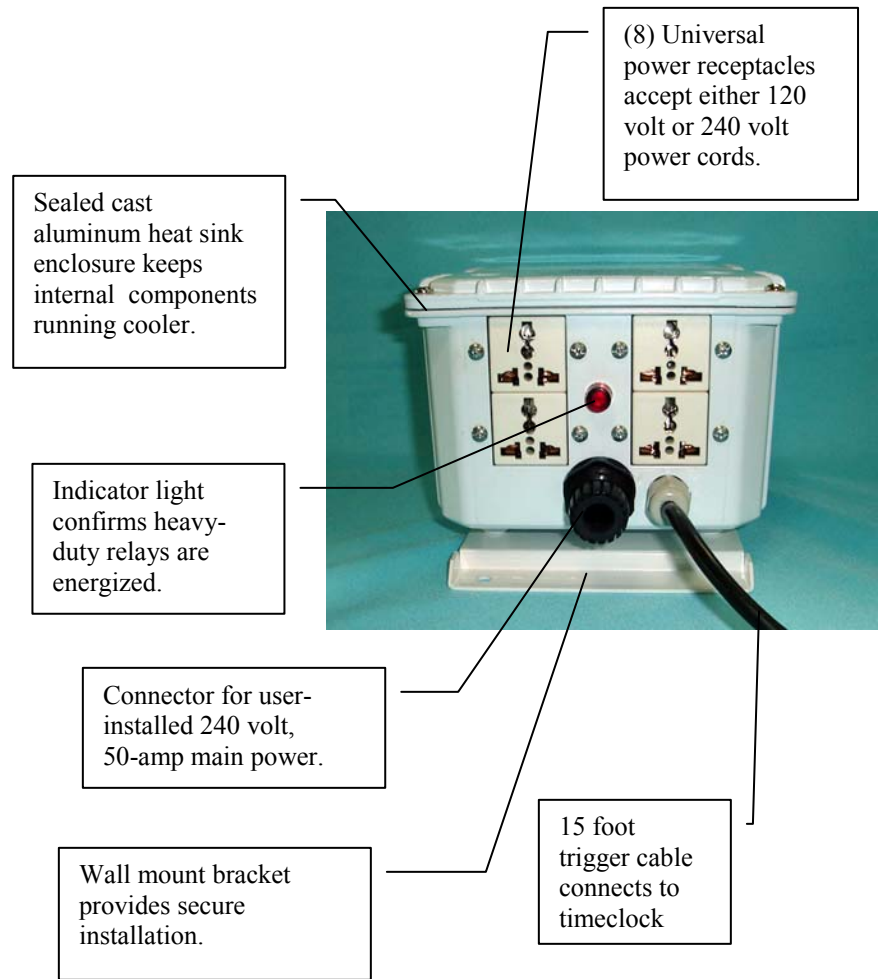

NOTE: The HPH-8 is a high-power device. Locate the HPH-8 away from other sensitive electronics. Even though the enclosure is sealed, DO NOT spray the unit with water... especially the receptacles. Provide a dedicated circuit to the HPH-8 with overload protection. (50-amp / 240 volt)

Installing the HPH-8

*120-Volt Option

In order to ensure a safe and proper installation of the HPH-48 follow the steps below.

- 1) Select the location for the device to be used. Keep the unit away from water. Determine where the trigger cable will be connected to the timeclock or controller. (Extension cords can be used to connect the trigger cable to the timeclock if necessary.)
- 2) Secure the HPH-8 to the bracket using the screws included with the unit.
- 3) The wall mount bracket can then be mounted to the wall using appropriate screws.
- 4) Remove the enclosure cover to expose the relay and terminals.
- 5) With the main power turned OFF, connect the main 240 volt / 50-amp power to the terminals provided inside the enclosure. (See diagram / photo on the next pages.)
- 6) **DO NOT** turn ON the main power yet. Connect the 120 volt trigger cable to the timeclock or controller that will be turning the HPH-8 ON & OFF.
- 7) Energize (over-ride) the timeclock or controller and verify the RED indicator light and the relays are energized. (The relays will “close” with a loud “clunk” noise when it is energized)
- 8) Once the trigger cable is tested, disconnect the trigger cable from the timeclock or controller. Replace the cover on the HPH-8.
- 9) Now turn ON the main power. The unit is now ready for use.
- 10) Ensure that the timeclock / controller that will be activating the HPH-8 is set to turn ON & OFF at the correct times. Reconnecting the trigger cable will complete the installation.

Important: **DO NOT** connect 120 volt devices to the receptacles on the HPH-8. **DO NOT** connect more than 8000 watts of lighting to the HPH-8. Only connect (1) ballast per receptacle.

WARNING: Installation must be completed by qualified person(s). Installation must be done in accordance with state and local electrical codes.

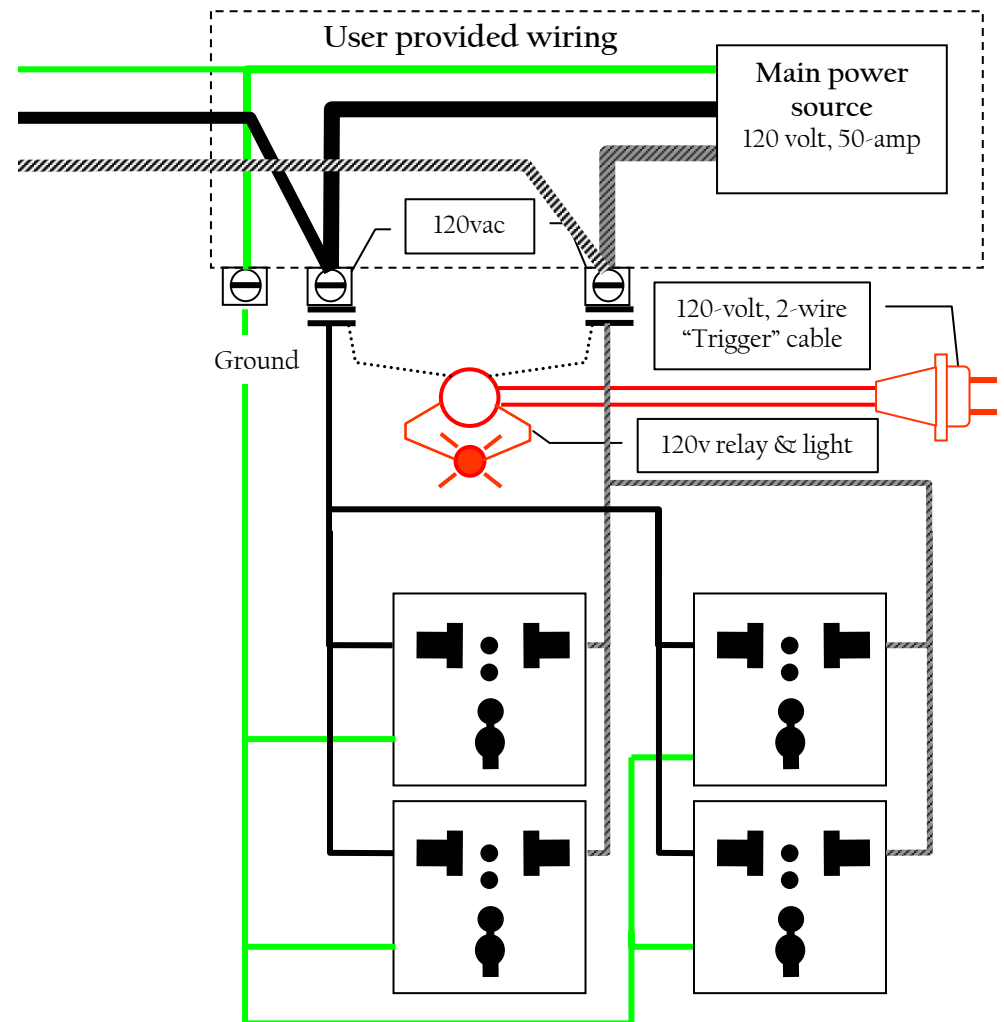

*120-Volt Option

The HPH-8 CAN be used to control ballast that are not capable of being operated on 240-volt power however, the number of ballast that can be operated is greatly reduced if they are operated on 120-volt. Here is a list of the number and wattages that can be used on 120-volt power.

250 to 400 watt = (8) ballasts
 600 watt = (6) ballasts
 1000 watt = (4) ballasts

Notice that only (4) 1000 watt ballast can safely be operated at 120-volt. Each 1000 watt ballast consumes 9+ amps each. The user must provide a single-pole, 50-amp circuit breaker and #6 AWG wire when used with 120-volt.

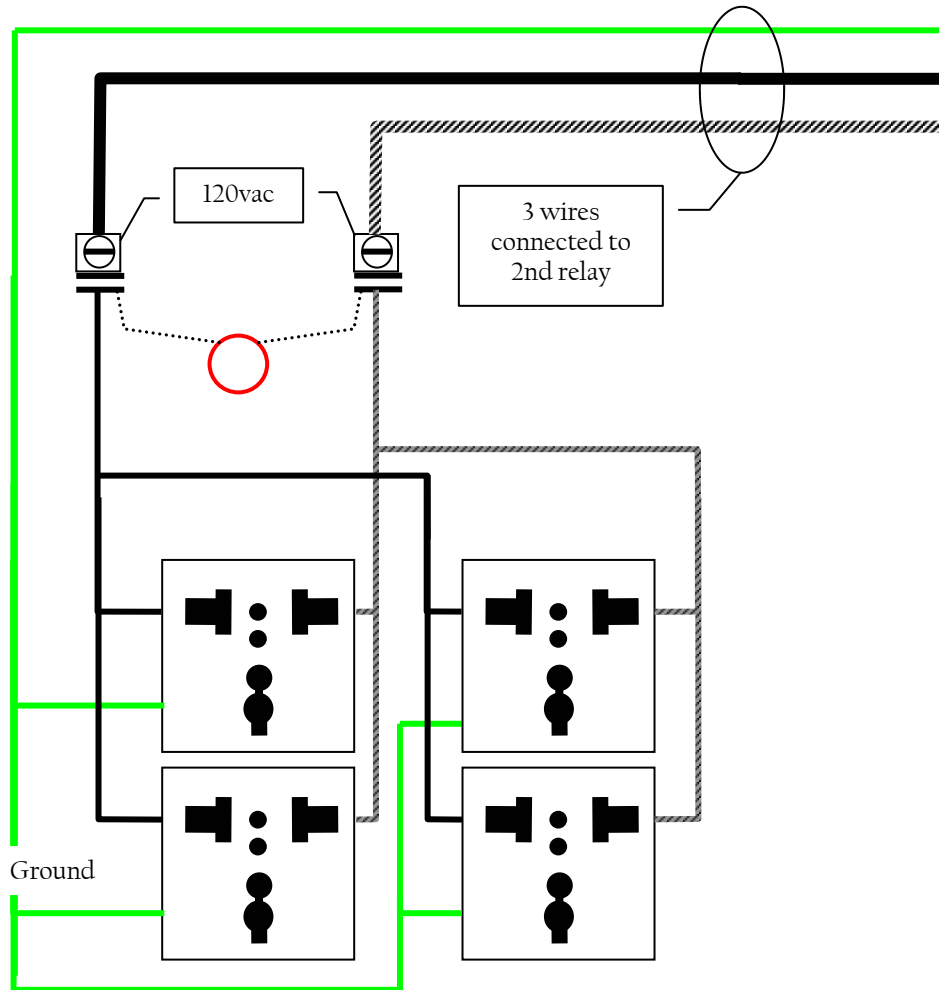

Installing the HPH-8



2 sturdy brackets can be used to fasten the unit to a wall.

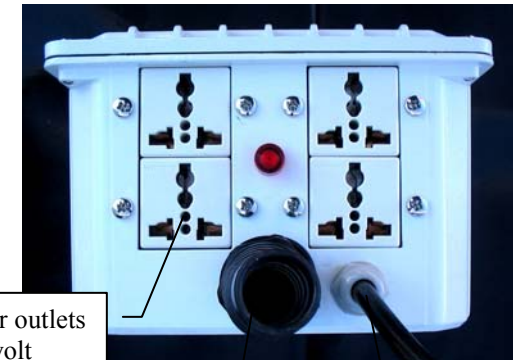

(8) Universal power outlets accept 120 or 240 volt power cables. HID ballasts are connected here.

50-amp / 240 volt main power cable is installed here.

Trigger cable is connected to any 120 volt timer.

Installing the HPH-8



50-amp / 240 power enters HPH-8 through cable connector.

Hid ballasts are connected to pre-wired receptacles.

User connects Main power bare or green ground wire connected here.

User connects (1) 120 volt wire from main power source here

User connects (1) 120 volt wire from main power source here

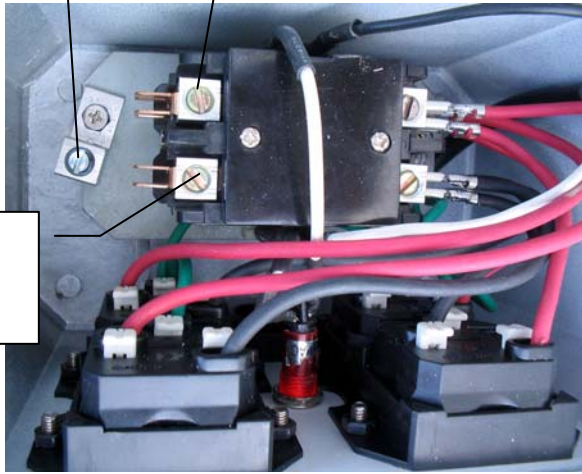

HPH-8 electrical connections (240 volt)

WARNING: Installation must be completed by qualified person(s). Installation must be done in accordance with state and local electrical codes.

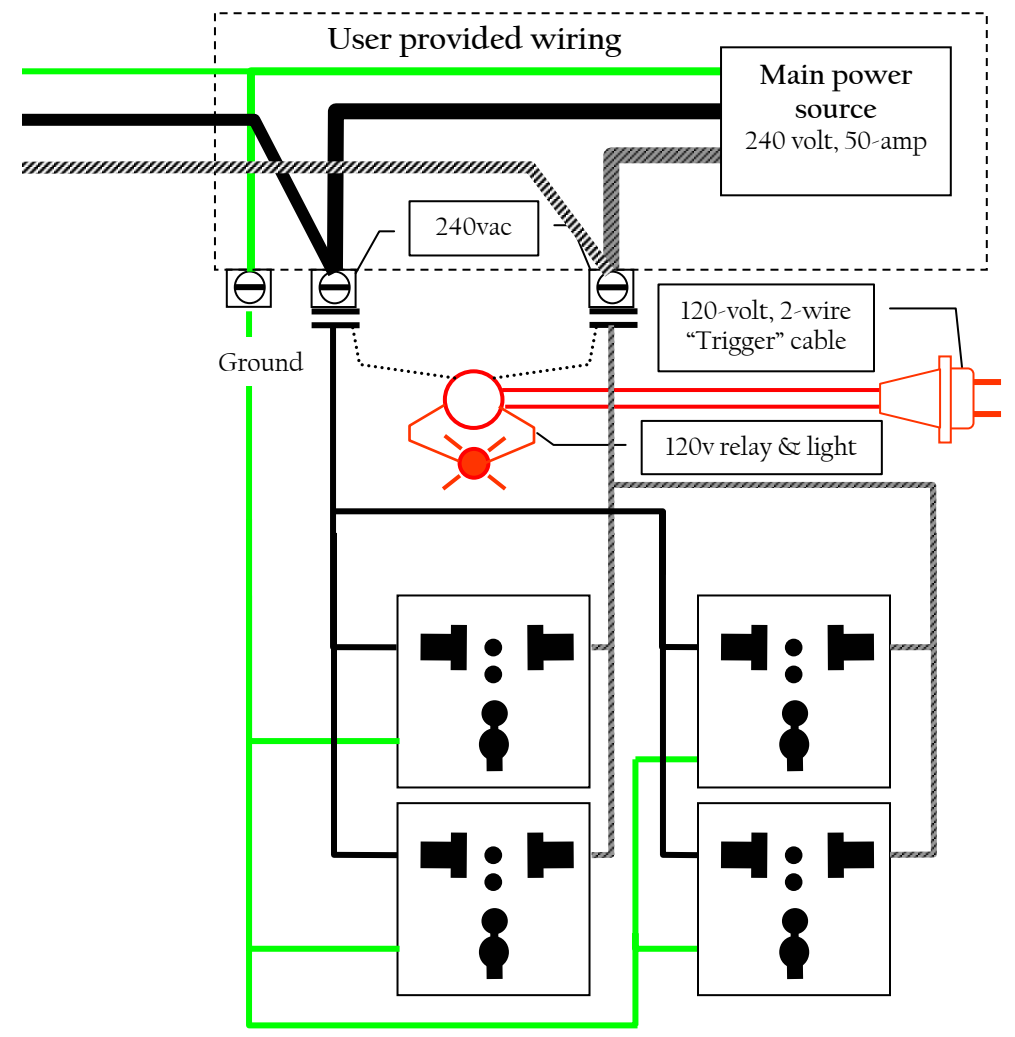

HPH-8 electrical connections (240 volt)

Most of the wiring inside the HPH-8 is already connected, but the main power needs to be connected by the installer.

3 large aluminum terminals are provided inside the HPH-8. The main power (50-amp @ 240 vac) is connected to the terminals by the user. A #6 AWG 3-wire cable is the correct size cable to use for 50-amps.

The user must also use a 50-amp 2-pole circuit breaker to protect the wiring and the HPH-8

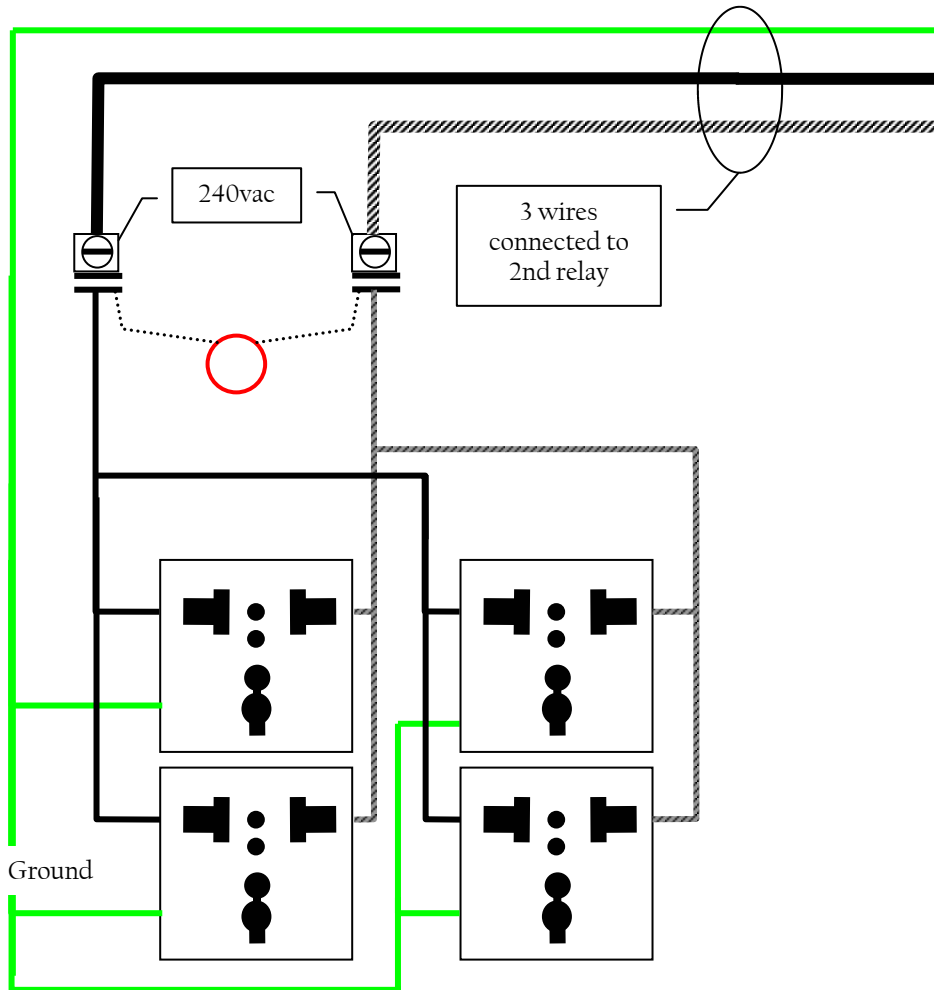

Using the HPH-8

The following describes the most common use for the HPH-8. Most users who are using multiple HID ballasts will need to make sure their ballast are wired for use on 240-volt power before connecting them to the HPH-8.

Unless your ballast have interchangeable power cables, it may be necessary to open the HID ballast enclosure and physically change the power connection inside the ballast. It is usually as simple as disconnecting the wire coming from the ballast transformer marked (120), and connecting the wire marked (240) to the ballast's power cord.

NOTE: The HPH-8 can also be used to control ballasts wired for 120 volt. You must exactly follow the instructions on page # 12 of this instruction manual. (See *120-Volt Option)

Because the HPH-8 has “**Universal receptacles**” that will accept a variety of different power cables, it is VERY important to double-check that all of the devices plugged into the HPH-8 are wired correctly for operation on 240-volt power.

If a 120-volt device is connected to a 240-volt power source, the device could be permanently damaged or even cause a fire. Be **ABSOLUTELY** sure your ballast are wired correctly before energizing your HPH-8 for the first time.

WARNING: Installation must be completed by qualified person(s). Installation must be done in accordance with state and local electrical codes.

Once the HPH-8 is connected to the main power source and the trigger cable is connected to the timeclock or controller that will activate the HPH-8, the lights connected to the HPH-8 will be turned ON & OFF automatically by the controlling device.

Connection examples

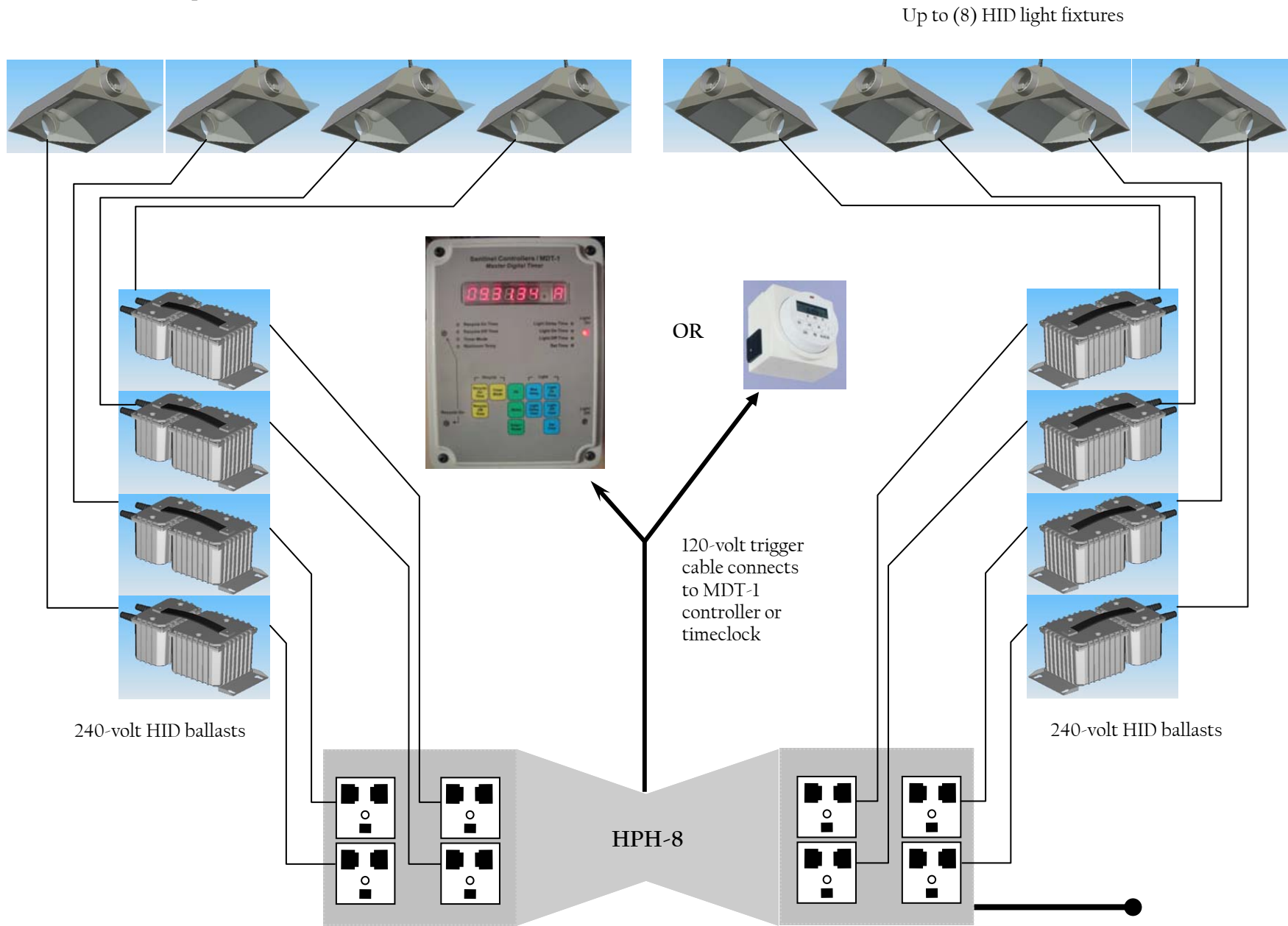

NOTE: Up to (8) ballasts equaling 8000 watts can be controlled by the HPH-8. Do not exceed the ratings of the unit.