

GENERAL HYDROPONICS® **EuroGrower®**

Assembly Guide

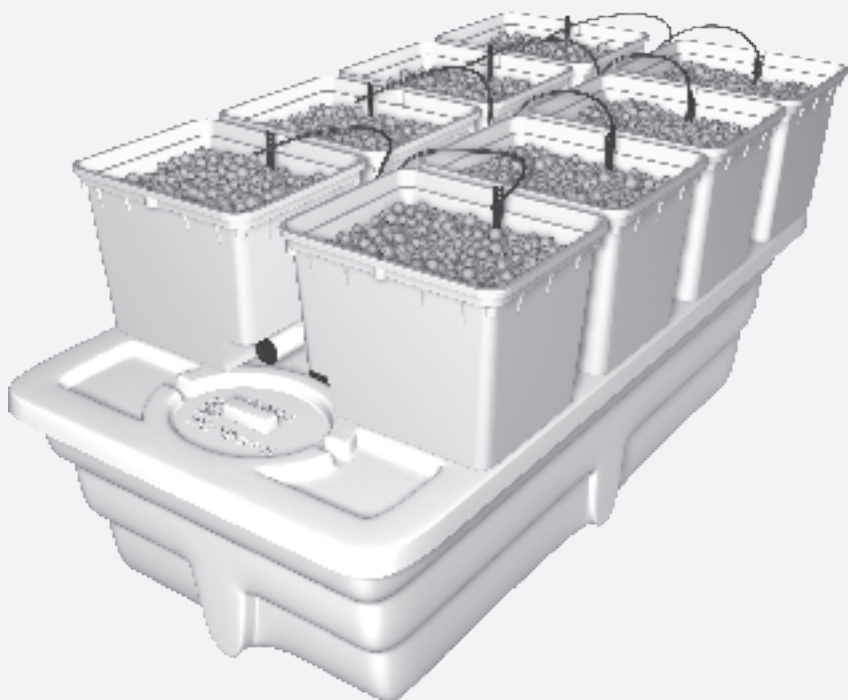

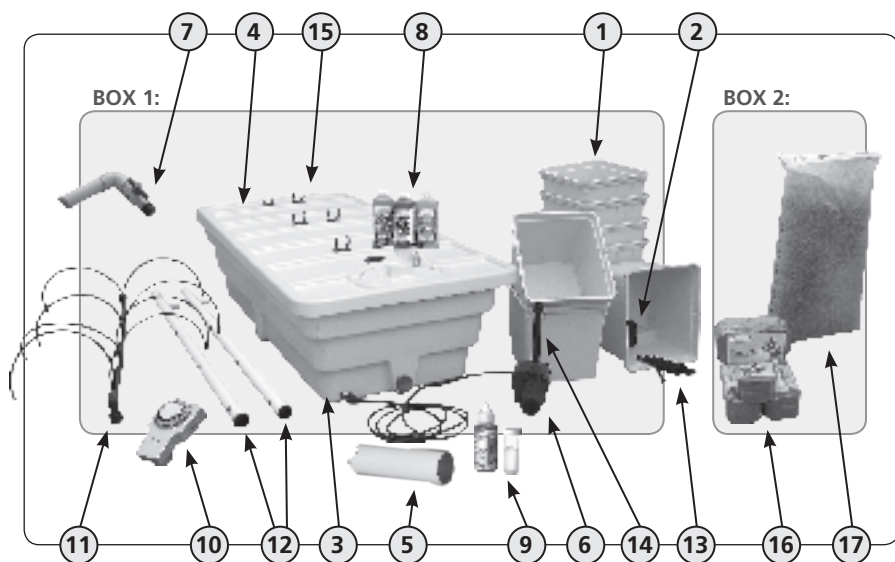

EUROGOWER PARTS:

BOX 1:

- 1) Bato Buckets (8)
- 2) Drain Elbows (8)
- 3) Panda 40 Gallon Reservoir (1)
- 4) Reservoir Lid (1)
- 5) Reservoir Lid Support (1)
- 6) Mag Drive #2 (1)
- 7) Drain Valve (1)
- 8) Flora Series Nutrients (3 Pints)
- 9) pH Test Kit
- 10) Grasslin Timer
- 11) Drip Feed Line
- 12) Drain Rails (2)
- 13) Drip Stakes (8)
- 14) PumpLine (1)
- 15) Drain Rail Clips (6)

BOX 2: *(not included with module)*

- 16) CocoTek Fine Coir Bricks (4)
- 17) Clay Pebbles (50lbs)

STEP 1

Place the **Panda Reservoir** on a level surface where it will be used. Coat the inside of the Reservoir grommet with a thin coating of silicon grease (optional) and insert **Drain Valve** into grommet using a twisting motion.

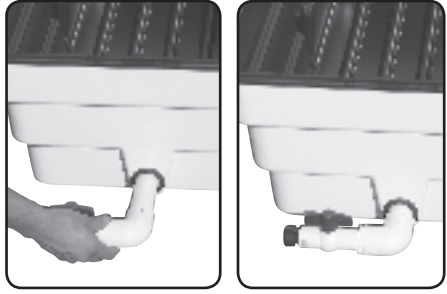

STEP 2

Attach the **Drain Rail Clips** by inserting them into the holes on the Reservoir Lid.

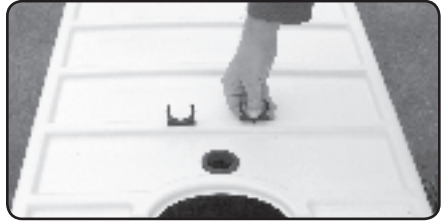

STEP 3

Place the **Lid Support** in the center of **Panda Reservoir** with the notch over the center rib and place the **Reservoir Lid** on top of Panda Reservoir. Proper positioning of Lid Support will prevent the Reservoir Lid from sagging.

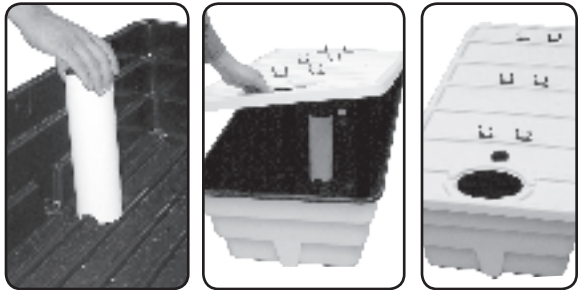

STEP 4

Position both **Drain Rails** on top of the Reservoir Lid and make sure Drain Rails rest in the Drain Rail Holes in the Reservoir Lid.

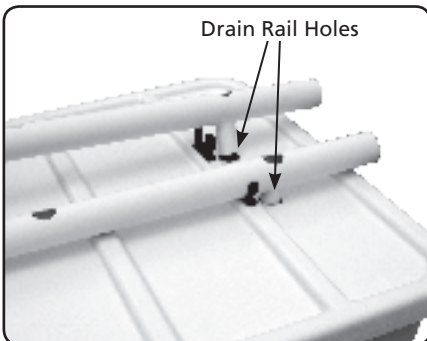

STEP 5

Place Filter onto **Mag Drive #2 Pump** and attach **Pump Line**.



STEP 6

Place **Mag Drive #2 Pump** into the **Panda Reservoir** through the Reservoir Access Hole and feed Pump Line and Power Cord through small hole located next to the Reservoir Access Hole.



STEP 7

Place the **Drip Feed Line** on top of the **Reservoir Lid** between the two **Drain Rails** and connect to the Pump Line. Cover the Reservoir Access Hole with the Access Lid.



STEP 8

Connect two **Drain Elbows** to create a Drain Fitting. Insert wide end of the Drain Fitting onto the plastic extension located on the bottom of the **Bato Buckets**. The smaller end of the Drain Fitting fits into the hole on the upper edge of Bato Bucket.



STEP 9

Place the **Bato Bucket** on top of the **Reservoir Lid** so the Bucket Drain rests in one of the Drain Rail Holes.



STEP 10

Make sure that Drip Lines reach into the **Bato Buckets** and attach them to the **Drip Stakes**. The Drip Lines fit best into second smallest opening of the Drip Stakes.

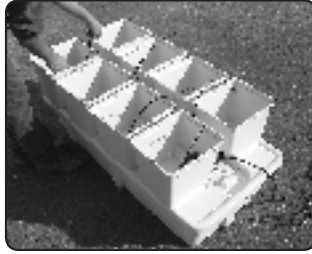

STEP 11

Rinse the **Clay Pebbles** thoroughly with plain water and fill each **Bato Bucket** up to the Drain Fittings. Set aside a similar amount of the Clay Pebbles for top mulch and the remaining Clay Pebbles will be mixed with **CocoTek Fine Coir Brick**.



STEP 12

Place one **CocoTek Fine Coir Brick** into a bucket and add 1 gallon of plain water to expand the brick. Once the brick has expanded and soaked up all the water transfer the soil like growing media to the **Bato Buckets** and repeat for each of the bricks. Mix in some of the **Clay Pebbles** as you fill the Bato Buckets and remember to leave some Clay Pebbles for topping off the buckets. Topping of the Bato Buckets with a thin layer of Clay Pebbles will help reduce algae growth.



STEP 13

Insert the **Drip Stakes** into the growing media and position the Drip Line towards the center of the **Bato Bucket**.



STEP 14

Plug the **Mag Drive #2 Pump** power cable into the **Grasslin Timer**. Use the timer to control when and for how long the system is watered. Set the time to come on in 15 minute increments by pushing the pin in at the time you want the system to water your plants. Rotate the timer dial to the correct time and plug into a properly grounded and fault protected outlet.

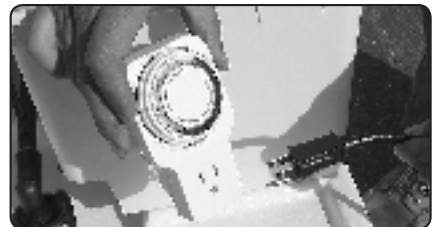

FILLING

When filling the system with a nutrient solution it is best to mix the nutrients in a known volume of fresh water and pour into the reservoir until the system reaches the desired level. The reservoir holds approximately 38 gallons at the highest operating level. You can mix a smaller batch if needed and the reservoir holds approximately 12 gallons at the first step and 28 gallons at the second step. Always maintain the water level to at least the first step and never allow the pump to run dry.

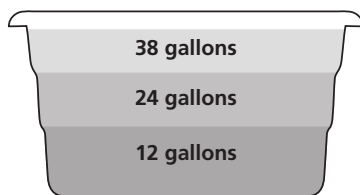

PLANTING

To prepare a seedling or a plant for transplanting, remove all soil and/or organic material from around the roots. Plants must be sturdy with established roots before transplanting into the EuroGrower. Choose seedlings because it's more difficult to successfully transplant older plants. If your plant has been growing in soil or peat moss, gently remove the plant from its pot and carefully rinse as much soil as possible from the roots before transplanting. Although this method of transplanting from soil to hydroponics is somewhat risky, as soil may contain disease organisms that proliferate in the rich hydroponic solution, we have had success using this transplant method and encourage you to try it. Or, you can avoid these problems by starting plants from cuttings in one of our RainForest Systems.



PLACEMENT

Abundant light, proper temperature and adequate ventilation are crucial for fast growth, healthy plants and higher yields. Place the EuroGrower in a warm, well-lit, well-ventilated location, such as an outdoor garden, sunlit window, patio or greenhouse. Keep your EuroGrower away from areas where the inevitable dripping that occurs during filling, draining and pH adjustment could cause water damage.

You can grow several small plants in the EuroGrower; evenly space out your plants in each of the Bato Buckets or you can grow a single large plant in each Bato Bucket. Gently add Clay Pebbles and CocoTek growing media mixture around the plant roots until thoroughly covered.

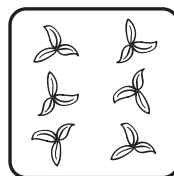

OPERATION

Depending on the growth stage and type of plant, you will need to adjust the timer to water your plants often enough to maintain sufficient moisture in the individual Bato Buckets. In general you will need to water more often during the daylight hours and less during the night. Use mild to normal strength nutrient solution and avoid strong or aggressive nutrient. As your plants consume nutrient solution, the level in the reservoir will drop. Top off with half strength solution or plain water, depending on your plants growth rate and needs. It is necessary to change the water and nutrients every one to two weeks depending upon the size of your plants and their rate of growth; with bigger plants change more often. Simply empty the reservoir by rotating the blue handle on the drain valve 90 degrees so water drains on the ground or connecting a hose to the drain valve when indoors.

PREPARATION FOR REPLANTING

After harvesting and before replanting your EuroGrower, dismantle the system and clean all parts with hot water. Rinse the Clay Pebbles in very hot water and soak overnight. It is also a good idea to dis-assemble the Drip Feed Line and wash the assembly and Mag Drive #2 from time to time in hot water.

TROUBLE SHOOTING

If white salt deposits form on the Clay Pebbles:

1. Try using a milder nutrient solution and topping off with plain water only.
2. Occasionally drain your system, refill with plain water and let the system run normally for a day. Afterwards, empty reservoir and refill with fresh nutrient.

If plants are not growing well and you suspect "hard" water:

1. Use FloraMicro Hardwater in place of FloraMicro.
2. Try distilled or purified water. You should see a significant improvement in plant health and growth within one week.

If nutrient solution stops flowing from the drip lines:

1. Check to ensure that pump is plugged in and reservoir is filled with nutrient solution.
2. Keep the pump and filter clean and use General Hydroponics FloraKleen™ to minimize nutrient buildup and crusting.

FLORAKLEEN®

- Dissolves accumulated fertilizer salts.
- Reduces plant stress from excess and imbalanced nutrients.
- Releases nutrient bonds between plants and systems, also correcting nutrient lock-out.
- Use FloraKleen as a final flush a few days before harvest to promote maturation and sugaring.
- Safe for all systems and media while plants are growing.

FloraKleen removes fertilizer residue that can accumulate over time in hydroponic systems, growing media, and potting soils. Use FloraKleen monthly to purge your hydroponic system or potted plants of excess salts that can accumulate as a result of regular fertilizer application. FloraKleen can be used at anytime throughout the plant's life and is an excellent final flush to help improve flavor. Its high concentration and low price make FloraKleen the economical choice for maintaining your plants in both hydroponic and soil based environments.





FLORABLEND®

FloraBlend is a Vegan Ferment Tea that is made from a proprietary blend of plant materials, plus seaweed, rock powders and micronized leonardite. FloraBlend is produced with a diverse mixture of highly bioactive microorganisms that are fed a feast of select food sources in a hyper oxygenated environment. These beneficial microorganisms multiply rapidly consuming these food sources and through bioconversion processes, new organic compounds are formed. These organic compounds are enzymes, metabolites and organic acids, which energize plants metabolic processes.

These highly soluble organic compounds increase and promote healthy root structures, build the plants immune system and provide carbon building blocks for plant processes responsible for color and flavor of fruits and vegetables.

COCOTEK® PREMIUM COCONUT COIR - 5KG BLOCK

The CocoTek 5kg block is 100% organic and consists of compressed coco coir. This high quality, low sodium, growing medium is an environmentally friendly alternative to sphagnum peat moss. When hydrated with water the Cocotek Block rapidly expands, saving you time and effort. GH Cocotek Blocks can be used exclusively by themselves, blended together or mixed with expanded clay pebbles, perlite or topsoil.

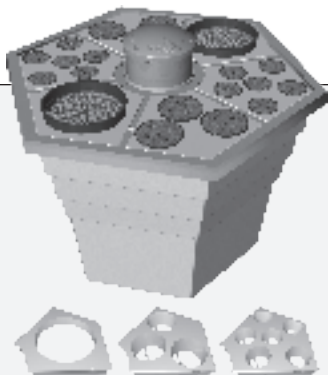

RAINFORREST®

The Rainforest is perfect for propagation or growing plants to full maturity. Our patented Vortex Sprayer provides a super-oxygenated mist for rapidly developing plants. With a compact design and small footprint, the Rainforest is available with 2", 3", and 6", site lid inserts to suit specific growing needs.



GH
genhydro.com

PO Box 1576, Sebastopol, CA 95473, USA

707-824-9376 Monday through Friday 9am to 4pm PST

p100208am ©2008 GENERAL HYDROPONICS