



CGC-1 Complete Greenhouse Controller

OVERVIEW

The CGC-1 Complete Greenhouse Controller from C.A.P. controls all of the main devices required in today's modern hydroponic garden.

WORD TO THE WISE...

CGC-1-----

Before attempting to operate the CGC-1, you should at least take the time to look at the Example Connection diagram on page 2 and read the "Start-up Procedure on page 3 of this manual. To get the most out of the CGC-1, familiarize yourself with this manual. It contains many useful hints; examples and a troubleshooting guide.



IMPORTANT STUFF TO REMEMBER

The CGC-1 is designed to operate from a 120vac, 15-amp power source. It can safely control up to 15-amps of equipment including up to 1000 watts of HID lights. If required, additional lights and larger equipment can be connected to the CGC-1 by using our HPR, MLCs or UPM "Universal Remote Power Modules".

In addition to lights, the CGC-1 also maintains the temperature and humidity by controlling your exhaust fan(s). CO₂ levels can be controlled with the built-in timers, which are coordinated with your exhaust fans and function only when the lights are ON. Or you can upgrade later to PPM Part-Per-Million control by adding the PPM-1c CO₂ monitor. And to complete the package, the built in Adjustable Recycling Timer is perfect for controlling your hydroponic pumps and more!

PROTECTION & SAFETY

The CGC-1 is overload protected a main 15-amp fuse. Do not exceed the maximum rating of the CGC-1.

IMPORTANT: Replace blown fuses with fuses of the same rating ONLY!

Note: A surge suppressor power strip is always recommended when operating electrical equipment such as the CGC-1.

WARRANTY

The CGC-1 is protected by our 3-year limited warranty. All components are warranted by R & M Supply against defects in workmanship and materials under normal use for 3-years from the date of purchase. The CGC-1 is 100% maintenance-free and does not require service.

INSTALLATION / START-UP

There are a few requirements for a successful installation and start-up.

- 1) The CGC-1 must be mounted in a vertical position. Mounting feet are included to allow you to secure the unit to a wall.
- 2) The CGC-1 requires "free air movement" to maintain temperature and humidity accuracy. The top and bottom of the enclosure has ventilation slots to provide air flow through the unit however, we greatly recommended using an oscillating fan in the growing area to provide fresh air for the internal humidity sensor and provide adequate ventilation for the internal electrical components.
- 3) A dedicated 120 VAC, 15-amp power supply is recommended. A ground wire (3-wire outlet) must be used. **Do not use 2-wire adapters or cords to operate the CGC-1.**
- 4) The CGC-1 must be protected from water. Do not mount the unit where it can be exposed directly to water.
- 5) Read the rest of the manual!!! It has been designed to take you through step-by-step to make start-up a breeze.

“FRONT PANEL”

OVERVIEW

“The CGC-1 is a self-contained greenhouse control system designed for people who want a reasonable, simple to operate, complete greenhouse controller.”

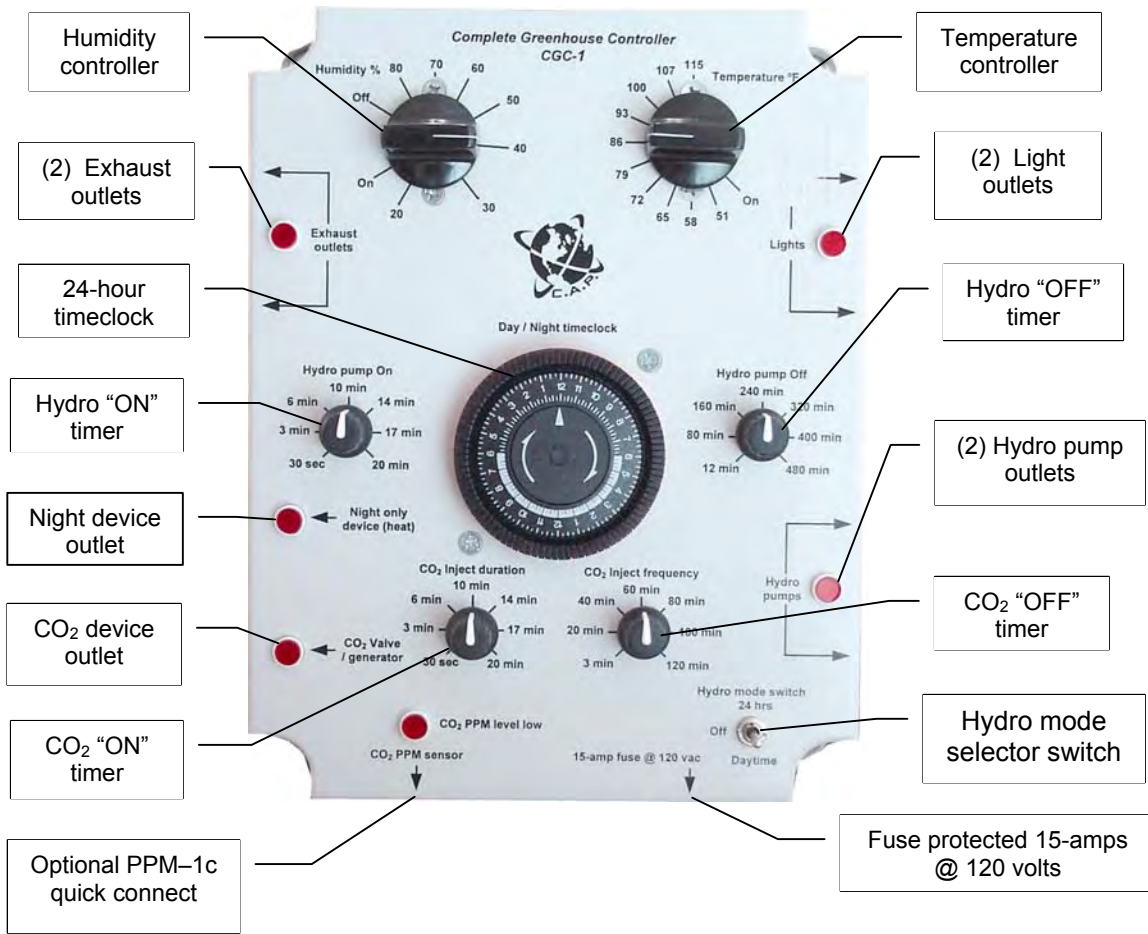

EXAMPLE CONNECTION DIAGRAM

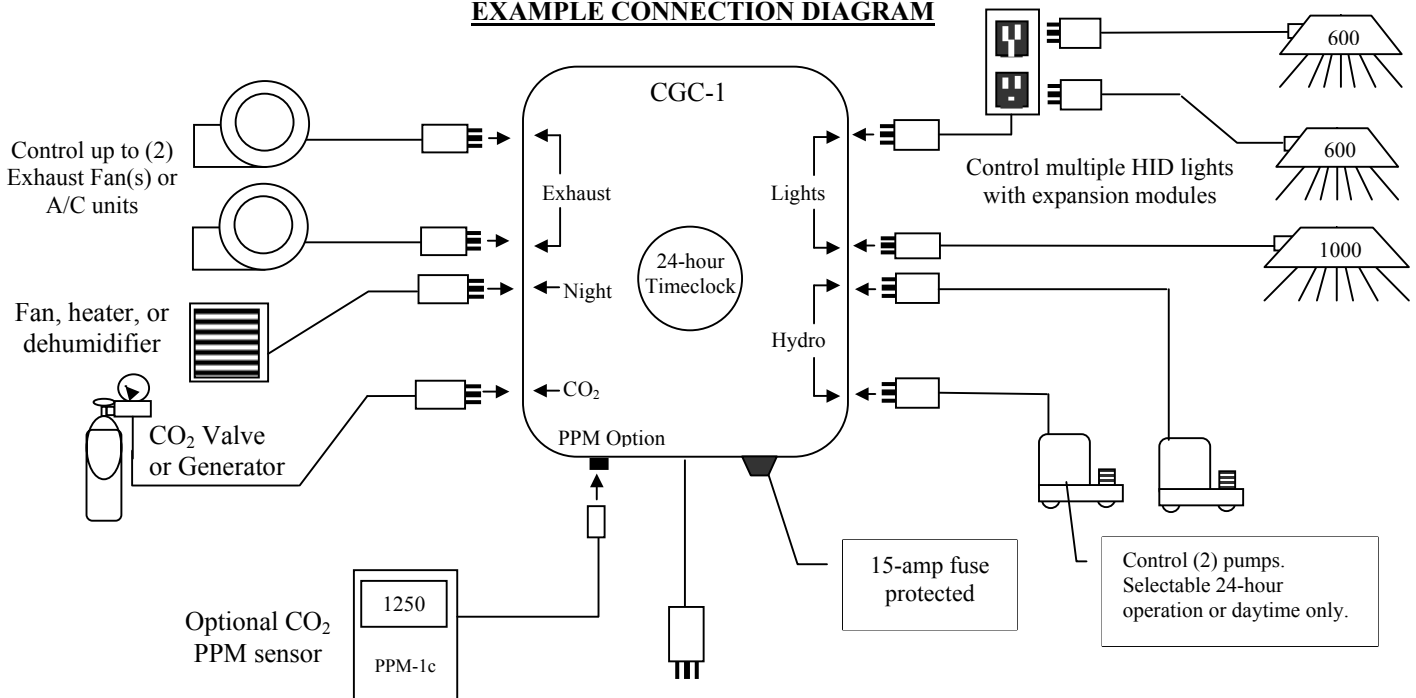

START-UP PROCEDURE

OVERVIEW

“There is no substitute for reading and understanding the operating manual however... You can use the instructions on this page for a trouble-free start-up”.

HOW TO START-UP THE CGC-1

- 1) Locate a suitable source for power. A “3-wire”, grounded, 15-amp dedicated circuit is recommended.
- 2) Secure the enclosure to a wall using the enclosed mounting “feet”. The CGC-1 requires a vertical orientation for proper internal ventilation. If proper ventilation is not provided, the thermostat may not be able to properly control the temperature & humidity of the growing area.
- 3) Plug the CGC-1 into the power source. Do not connect your lights until you have set the “ON and “OFF” times on the 24-hour timeclock.
- 4) If you are using a PPM-1c CO₂ sensor, connect it by removing the “jumper-plug” provided with the CGC-1 and connecting the PPM-1c quick-disconnect. Plug the PPM-1c into a source of constant 120-volt power. Refer to the PPM-1c instructions for information on how to operate the PPM-1c properly.
** Note: The pre-wired “jumper plug” must be connected if the PPM-1c is not being used!*
- 5) You can now set the thermostat and de-humistat to the approximate settings you would like to use. A small, inexpensive combination thermometer and hygrometer works just fine to “dial in” the exact settings. Just compare the reading on the thermometer to what the CGC-1 is set at and adjust as required.
- 6) You can now select the Hydro mode you would like to use. Choose between operating the Hydro outlet during the “Daytime” only or, 24-hours a day. Move the Hydro mode switch to the appropriate position. Moving the switch to the center “OFF” position momentarily will reset the timer.
- 7) There are 4 timers on the CGC-1 which are used to control a hydroponics pump and a CO₂ valve or generator. To fully understand the timers that control the CGC-1, refer to the Timers section of this manual. Set the Hydro and CO₂ timers to your desired settings before continuing. (Refer to Timers)
- 8) The 24-hour timeclock can now be set. Push in the trip levers on the front face of the timer dial for the time you want your lights to be “ON”. Rotate the dial to the current time to set the timer.
- 9) You can now plug the equipment you will be using into the appropriate receptacles. Remember that the CGC-1 can handle a combined load up to 15-amps. A single 1000-watt HID ballast needs over 9-amps alone. Select and size your pumps and fans appropriately or use our UPM-1 or MLCs to increase power capacity.
**Note: We highly suggest NOT plugging in your HID ballast just yet.*
- 10) When the “day” cycle begins, the “Lights” indicator will light up to confirm power is going to the (2) light receptacles. If you have selected the “Daytime” setting on the Hydro mode, the “Hydro Pumps” indicator will also light up to indicate your pump is powered for the amount of time you selected
- 11) You can manually override the timeclock to switch from “night” to “day” or back to Night by rotating the outer dial of the timeclock slowly clockwise. At night, the Lights and CO₂ are disabled while the thermostat and humistat continue to control the temperature and humidity.
** NOTE: The Hydro outlet will also be disabled if the “Daytime” mode is selected on the Hydro mode switch.*
- 12) When all settings have been confirmed, the HID lights or UPMs can be plugged into the “Lights” receptacles. If more than 1000 watts are to be controlled, use our Universal Power Modules or the MLCs.
** IMPORTANT: Do not plug in more than 1000 watts worth of lighting into the CGC-1 receptacles.*
- 13) Monitor the equipment connected to the CGC-1 to ensure proper operation. Small adjustments are likely to be made until you find the right combination of controls. Once you are happy with the settings sit back and enjoy the show!

For more details concerning any of the CGC-1 functions, refer to the appropriate section of this manual.

“CONTROLS”

OVERVIEW

“The CGC-1 controls your light cycles, temperature, humidity and CO2 levels... automatically! No more guesswork! The CGC-1 lets you work smarter not harder.

24 HOUR, TIMECLOCK

The timeclock selected to run the CGC-1 performs all of the day to night transitions required for crops requiring controlled photoperiods. It can directly control up to 1000 watts of HID lights.

To set the current time on the timeclock, turn the dial clockwise until the current time on the outer dial lines up with the arrow on the inner dial. To set the timeclock on and off times, carefully push in each of the orange trip levers at the times you want the lights to be on.

***NOTE: If power is interrupted, the timeclock will have to be reset.**

TEMPERATURE CONTROLLER

The CGC-1 utilizes a remote-bulb thermostat with a 36” lead to control ventilation and cooling functions. This allows you to place the temperature sensor up to 36” away from the CGC-1. The thermostat can be set to control temperature from 50 – 115°F.

The thermostat is coordinated with the CO₂ control system and the exhaust receptacles to maintain a constant temperature. When the temperature rises above the set point selected on the thermostat, the CO₂ system is disabled and the Exhaust receptacles are enabled. When the temperature level drops below the set point, the CO₂ system is re-activated.

IMPORTANT: To achieve the greatest accuracy, provide the CGC-1 with plenty of “fresh air”. The enclosure is designed to allow air to pass over the humidity sensor.

HUMIDITY CONTROLLER

The CGC-1 utilizes a de-humistat to control ventilation and humidity levels. The de-humistat can control humidity levels from 20% - 80%.

The de-humistat is coordinated with the CO₂ control system and the exhaust receptacles to maintain a constant humidity. When the humidity rises above the set point selected on the de-humistat, the CO₂ system is disabled and the Exhaust receptacles are enabled. When the humidity level drops below the set point, the CO₂ system is re-activated.

HYDRO MODE SELECT SWITCH

The Hydro mode select switch is used to select whether the hydro outlet will cycle 24-hours or only during the day. The mode selector switch also doubles as a Hydro bypass switch. Each time the switch position is changed to the center “OFF” position, the hydro timers will reset and initiate a new cycle. This comes in handy during set-up of the hydro pumps and timer settings.

NOTE: *Leaving the mode select switch in the center position disables the hydro function.

NIGHT ONLY DEVICE

An additional outlet is provided which is powered only at “night” when the lights are turned OFF. This works great for heaters, fans and dehumidifiers, which need to run only at night.

PPM CO2 OPTION

The CGC-1 has a standard timed CO₂ control sequence, which can be improved upon greatly by simply connecting the optional PPM-1c. Simple operation, user selectable set point and on-board calibration makes the PPM-1c the perfect companion to the CGC-1.

TIMERS

OVERVIEW

The CGC-1 uses 4 timers to control the hydroponics and CO₂ functions. Two of the timers control the hydroponics pump frequency and duration, and the other two determine CO₂ injection / generation time and frequency / sample time.

ADJUSTABLE RECYCLING TIMERS

Adjustable recycling timers provide an adjustable “ON” / “OFF” cycle for various devices. The 4-adjustable recycling timers onboard the CGC-1 are set using the dial on the front face of the enclosure. The timer name and range of each timer is printed around the timer dials. Because the dials of the CGC-1 are small to conserve space, the settings may have to be adjusted to an actual time setting. If necessary, use a watch or stopwatch to confirm the settings are correct. Once the timers are set, they are repeatable to +/- .5%.

The timers are designed to finish the cycle they are presently timing which means adjustments made to the timers during a cycle will not affect the present cycle.

IMPORTANT: In order for the timers to accept a new setting, the timer must either complete it’s present cycle or, power must be cycled off, then on.

RESETTING HYDRO TIMERS: The Hydro timers can be reset by switching the Hydro mode select switch to the center “OFF” position **momentarily**.

RESETTING CO₂ TIMERS: To reset the CO₂ timers and restart the CO₂ cycle, turn the temperature or humidity controller down momentarily. This will trigger the “end of cycle” sequence and start the Exhaust duration timer.

RESETTING ALL TIMERS: If you choose to cycle power to accept new timer settings, we recommend disconnecting the lights prior to setting these timers. Disconnecting the lights will eliminate the chances of damaging the lights by cycling power “ON” and “OFF” to the lights. Follow the procedures below to set the Hydro and CO₂ timers correctly.

HYDROPONICS TIMERS

The Hydroponic outlet can be configured to cycle one of two ways... 24-hours a day or, during the “daytime” only. Simply moving the Hydro Mode selector switch to either the “24-Hour” or the “Daytime” position enables the desired mode. When used in the “Daytime” mode, the Hydro outlet will only cycle while the lights are on. The “24-hour” mode works great for NFT or aeroponic systems that require moisture during the day and night. The mode selector switch also doubles as a Hydro bypass switch. Each time the switch position is changed, the hydro timers will reset and initiate a new cycle. This comes in handy during set-up of the hydro pumps and timer settings.

There are two timers that control the hydroponics receptacle, Hydro “ON” and Hydro “OFF”. The CGC-1’s Hydro “ON” time can be set from 30 seconds to 20 minutes; the Hydro “OFF” time can be set from 12 to 480 minutes. Set the timers by moving the dial to the appropriate position.

CO₂ TIMERS

The CGC-1 controller also provides an integrated timed CO₂ control system. As with all of CAP’s greenhouse and CO₂ controllers, a thermostat and a de-humistat are used to interrupt CO₂ use if the temperature or humidity rises above the preset level. The CO₂ is also disabled at “night” by the 24-hour timeclock.

During the “day”, the CGC-1 controls your CO₂ valve or generator by turning the CO₂ outlet on for a certain amount of time and then off for a pre-determined amount of time, repeatable +/- 2%.

The CO₂ Inject timer or “ON” time can be set from 30 seconds to 20 minutes. The CO₂ inject frequency timer or “OFF” time can be set from 3 minute to 120 minutes. This provides a great deal of flexibility and control options.

For more detailed information about the CO₂ timers and sequence, refer to the CO₂ Control section of this manual.

CO₂ CONTROL

OVERVIEW

“Pound for pound, dollar for dollar, the CGC-1 offers one of the most advanced environmental / light / hydro and CO₂ control system on the market”.

“SUPPLEMENTAL CO₂”

Let's talk about ... Carbon Dioxide. CO₂ is present in relatively low quantities, (300-600 PPM) in your normal, generic, run of the mill everyday air. But plant growth can be increased and accelerated if the level of CO₂ is increased to, let's say... 1000 - 1500 PPM. For this reason, the CGC-1 can control CO₂ distribution for those people who prefer to use supplemental CO₂.

There are some inherent dangers associated with using CO₂. Here are some of the rules to remember when using CO₂:

- A) Cylinders (bottles) of compressed CO₂ should never be stored inside the growing area or anywhere else where the temperature may rise above 100°f.
- B) The growing area should not be occupied while CO₂ is in operation. (Get out!)
- C) Do not enter the growing area until the CO₂ has been exhausted. (Stay out!)
- D) CO₂ is heavier than air and will accumulate towards the ground. (Don't lie down on the job!)
- E) In high enough concentrations CO₂ can kill!!! The OSHA maximum “Personal Exposure Level” is 5000 PPM.

***Note:** The CGC-1 CO₂ control system can be used for both compressed CO₂ cylinders, and generators. The CO₂ receptacle is 120vac. Compressed CO₂ cylinders require an approved regulator / flow gage and a valve.

If optimum CO₂ “mileage” is desired, a self contained air conditioner or other “Closed loop” cooling method is highly recommended. A closed loop system will regulate temperatures within the zone allowing you to extend the CO₂ maximum cycle time thus reducing CO₂ use dramatically.

Another method of reducing heat build up includes utilizing “Ventilated light hoods”. Just be sure to make the ventilation system of the hood as airtight as possible so that your precious CO₂ is not being drawn out of the area by the ventilated hood exhaust fan.

If sufficient CO₂ is provided and the proper level of nutrients and light is available, a 35% increase in growth rate is possible. However if you suspect the higher temperatures are adversely affecting the plants, a shorter CO₂ cycle may produce better results. Remember that a shorter CO₂ cycle duration translates to increased CO₂ usage. Each application is different, so there is some work involved in finding the optimum set-up.

CO₂ CONTROL MODES

The CGC-1 provides both a standard timed CO₂ mode and an optional integrated CO₂ PPM control mode. Of course, the time clock will ensure CO₂ is only used during the “day”. The optional PPM-1c sensor is one of the most precise and efficient method of distributing CO₂. The PPM-1c control will be described later, but first, let me explain how to operate the standard timed CO₂ system.

***Note:** The pre-wired “jumper-plug” is used to bypass the PPM controller functions when the PPM-1c is not used.

Make sure it is properly connected when running the timed CO₂ sequence.

TIMED CO₂ CONTROL MODE

- 1) The CO₂ Inject Duration timer can be set from 30 seconds to 20 minutes. When the CGC-1's standard 24-hour timeclock switches to “daytime”, the CO₂ cycle begins. The CO₂ outlet is energized for a predetermined amount of time using the CO₂ Inject Duration timer.
- 2) The CO₂ Frequency timer works in conjunction with the CO₂ Injection timer. This timer can be set from 3-120 minutes. During the CO₂ cycle, the CO₂ outlet will be turned off for the amount of time set on this timer. The CO₂ Inject Duration timer and the Frequency timer continue to recycle until the thermostat or humistat turns on the fans. When the exhaust is turned back off, the CO₂ cycle is re-started.

Note: *These two timers continue to function in harmony with the optional PPM-1c sensor. The PPM-1c simply tells the CGC-1 whether the CO₂ level being measured is above or below the adjustable set point on the PPM-1c. The timers still control the CO₂ “ON” and “OFF” time.*

PPM (Part-Per-Million) CO₂ CONTROL MODE

As mentioned previously, the CGC-1 can control CO₂ levels within the growing area with “Part-Per-Million” accuracy when used in conjunction with the PPM-1c controller. Simply removing the jumper plug and connecting the PPM-1c into the standard quick-disconnect on the bottom of the CGC-1 instantly gives you the ability to fully control all atmospheric conditions which affect timed CO₂ systems.

*Note: The CO₂ Frequency timer acts as a CO₂ sample timer when using the PPM-1c controller. Because it may take a couple of minutes from the time CO₂ is released for the PPM-1c to detect a higher CO₂ level, this timer will provide a delay for the PPM controller to sense this increase in the CO₂ level before releasing more CO₂. If you find the CO₂ level is “overshooting” the CO₂ set-point, try increasing the CO₂ sample timer or decrease the CO₂ Inject timer. This will give the PPM-1c more time to sense the rise in CO₂ resulting in reduced “overshoot”.

THE PPM-1c

The PPM-1c controller consists of an infrared detector capable of measuring atmospheric CO₂ levels from 0 to 5000 PPM. The PPM-1c is powered by an 18 to 24vdc power supply. When it is connected, it will enter a “warm-up” mode. Once the PPM-1c has completed the “warm-up”, it will begin to self calibrate. This may take an additional minute. During this time, the digital readout may be fluctuating, this is normal. When the digital readout stabilizes, a level between 350 to 650 should be displayed. Be careful however, simply breathing on the PPM-1c controller will greatly increase the CO₂ level in the air resulting in a higher reading.

IMPORTANT!!! Do not start a CO₂ cycle until the PPM-1c has completed the “warm-up” and the display has stabilized.

Once the PPM-1c has been connected, it remains powered as long as it is plugged in. The controller will continuously display the exact CO₂ PPM level in part per million. The PPM-1c then transmits that information to the CGC-1 and displays it on the front panel by illuminating the “CO₂ PPM level low” indicator.

The PPM-1c is a portable device and comes with a 5-foot cable so that spot checks can be made.

A simple procedure allows the user to check and reset calibration... otherwise; the PPM-1c requires no adjustment or service.

Warning: Be careful not to expose the **PPM-1c** to water, as it is **not water-resistant!**

OPTIONS

OVERVIEW

The CGC-1 can be upgraded and expanded by using our expansion devices including the UPM-1, MLC-4 or the precision PPM-1c. The Universal Power Modules and Master Light Controllers allow you to run multiple pumps, fans and lights by controlling remote relays. The PPM-1c allows you to control CO₂ with Part-Per-Million accuracy!

UNIVERSAL POWER MODULE (UPM-1)

The UPM-1 Universal Power Module is a unique device that can allow the user to run additional HID lights or control multiple fans / air conditioners etc.

The UPM-1's "plug-box" was designed to be plugged into a standard household outlet. The 16-foot long "trigger cable" coming from the UPM-1 is then connected to your control device such as a time clock or thermostat. When the control device turns ON, the relay inside the UPM-1 box applies power to the twin outlets on the front of the UPM-1 turning ON whatever is plugged into it. This allows you to run additional lights etc. from a different circuit with one common control device.

The UPM-1 is rated at 15-amps @ 120 volts.



PART-PER-MILLION CO₂ SENSOR (PPM-1c)

To take full advantage of supplemental CO₂, you must be able to precisely control the level of CO₂. This is made possible by plugging in our "CO₂ Controller", the **PPM-1c**. The **PPM-1c** controller is constantly sampling the level of CO₂ in the growing area and can measure from 0 to 5000 PPM. The **PPM-1c** displays the current CO₂ level in PPM using large a 4-digit LED display. It then transmits that information to the CGC-1.

The PPM-1c is powered by a 18-24vac power supply.



MASTER LIGHTING CONTROLLER (MLCs)

The MLC-4 and MLC-4a Master Lighting Controllers are the best devices for controlling up to (4) HID lights from one time clock or controller. Like the HPR-1, power must be brought into the "input" side of the control relay. The MLC-4 features (4) standard 240v outlets, which your ballasts are plugged into. The MLC-4a is designed for 120 volt ballasts however it can also be used to run ballasts wired for 240-volt operation, which have 120-volt power cords. The MLC-8 Master Lighting Controller is the best device for controlling up to (8) HID lights from one time clock or controller. Power is brought into the MLC-8 by hardwiring up to a 40-amp circuit. The MLC-8 features (8) standard 240v outlets, which your ballasts are plugged into.

The MLCs both feature a 120-volt trigger cable to plug into a standard 24-hour timer or controller. The MLC-4 & MLC-4a are rated 30-amps @120/240 volt. The MLC-8 is rated at 40-amps @ 240 volt.



HID LIGHTING CONTROLLER (HLC-2)

The HLC-2 HID lighting controller was primarily designed to protect your expensive HID lights from HOT-STARTS.

A "Hot-Start" occurs whenever your lights are turned off... and then back on before the lamps are allowed to cool off. Hot-starts caused by power outages reduces your lamp's life and intensity. It can be plugged into either of the "Lights" outlets.

When the HLC-2 is connected to your lights, it will sense a power interruption, and start a 15-minute time-delay to keep the lights from trying to re-fire while the cool down. The HLC-2 can also be used to delay other devices from starting.

The HLC-1 is rated for 15-amps @ 120volts.



TROUBLESHOOTING

If you are having problems with this unit, refer to these troubleshooting hints. Also, refer to the connection diagram to ensure your devices are connected properly.

<u>Problem</u>	<u>Suggested Action</u>
◆ I have no lights and no function at all.	◆ Check the fuse and main power. Replace the fuse if required with the correct rated fuse. ◆ Check the equipment connected to the CGC-1 for problems and/or short circuits.
◆ The fuse continues to blow.	◆ If the fuse blows repeatedly, verify the devices connected to the unit are working properly and that they are not too large for the CGC-1 to safely control. ◆ You may need to consider using expansion modules, (UPM / HPR / MLC) to decrease the amperage (load) on the CGC-1 fuse.
◆ My CO ₂ outlet never comes on.	◆ Verify the PPM-1c jumper or the PPM-1c is connected. If you are using a PPM-1c, the "PPM level low" light will be on when the actual measured CO ₂ level is below your desired set point. If the "PPM level low" light is not "ON" the CO ₂ outlet will not energized. ◆ If the Exhaust outlet is ON, the CO ₂ will not be allowed to run. Turn up the Temperature and Humidity to a higher setting. ◆ In order for the CO ₂ outlet to function, the timeclock must be in "Daytime" mode. The CO ₂ is only activated when the lights are "ON".
◆ The fans are running so often, the CO ₂ is hardly ever ON.	◆ You may have too much heat building up in your area or too small of an exhaust fan. Reduce the heat sources or increase your fan size. ◆ You may also consider using a "closed-loop" air conditioner to keep the temperature and humidity below the set points so that CO ₂ is allowed to run for longer amounts of time.
◆ My CO ₂ consumption seems to be quite high.	◆ Make sure your area is sealed. You may want to install a motorized damper to seal your exhaust fans when they are "OFF". Even though the CGC-1 operates a standard "timed-release" sequence, you may still be "wasting" CO ₂ . ◆ If you are operating compressed CO ₂ valves, consider purchasing the optional PPM-1c "Part-Per-Million" sensor to upgrade to PPM control. The PPM-1c offers a significant improvement in CO ₂ efficiency.
◆ The CO ₂ level "overshoots" the PPM-1c set point considerably.	◆ When using the PPM-1c, the CO ₂ timers still control the "duration" of the "ON" and "OFF" time of the CO ₂ valve or generator. Small areas need less "Inject Duration" time than do larger areas. Larger areas need more "Inject Frequency" time in order to give the CO ₂ time to "mix" properly with the ambient air and measured by the PPM sensor. ◆ Start with lower CO ₂ timer settings for small areas and increase the timer settings for larger ones.
◆ The Hydro pumps are not cycling properly.	◆ The Hydro pump outlets can be operated 24-hours a day or only when the "Lights" are "ON". The "Hydro" selector switch also has a center "OFF" position, which can be used to "reset" the timing function. Make sure the switch is not turned "OFF".

MAKING CONNECTIONS

All of the main functions controlled by the CGC-1 are accessed using (8) standard 120 VAC, 15-amp receptacles mounted on the sides of the enclosure. This allows you to simply "plug in" any standard device without hardwiring or hassles. Printed labels on the front face of the enclosure identify the receptacles.

We highly recommend using only 3-wire devices with a ground. Suitably double-insulated devices are acceptable. Keep in mind that the combined amperage draw on all of the devices connected to the CGC-1 must be less than 15-amps @ 120 VAC.

MAINTENANCE / SPECIFICATIONS

SPECIFICATIONS:

System operating voltage	120vac +/- 20% @ 50-60 Hertz
Maximum Switching amperage	15-amps @ 120vac
Overload protection	15-amp normal blow fuse
Operating temperature	0 - 50° C / 32 - 122° F
Maximum humidity	95% RH (Non-condensing)
Temperature control range	50-115° F with a 7° F differential, +/- 3.6°
Humidity control range	20 - 80% RH with a 5% differential
Adjustable timer repeatability	+/- .5% under fixed conditions
Timer setting accuracy	+/- 10%
Hydro "ON" timer	30 seconds to 20 minutes
Hydro "OFF" timer	12 minutes to 480 minutes
CO2 Inject duration timer	30 seconds to 20 minutes
CO2 Inject frequency timer	3 minutes to 120 minutes
24-hour timeclock accuracy	+/- 3% monthly
Dimensions	10" X 8" X 7"
Weight	Less than 6 lbs.
Relay operations	Minimum 100,000 electrical / 10,000,000 mechanical

MAINTENANCE:

- 1) Consult the troubleshooting chart for a listing of the most common problems.
- 2) DO NOT open the enclosure!!! There are no components that require maintenance.
- 3) Do not use this equipment for purposes other than what it is designed for. It will provide many years of trouble-free service when used properly.
- 4) In the event you cannot solve the problem, first consult the dealer who sold the unit then contact the factory for instructions on how to return it to the factory for repair.

**PUBLISHED BY R & M Supply INC.
COPYRIGHT 2002 BY R & M Supply
ALL RIGHTS RESERVED.**

Liability statement:

R & M Supply and their retailers and distributors are not responsible for any damage or injuries (consequential or otherwise) arising from the use of this device. The purchaser assumes all responsibility for the use and proper installation of this device.